



Project \_\_\_\_\_  
Item # \_\_\_\_\_  
Quantity \_\_\_\_\_

## Commercial Water Boilers

Models: EWB-50A | EWB-100A | EWB-100A-I

Always have hot water handy with the Winco water boiler. This water boiler is sure to be a great additional to any hot beverage service.

### Standard Features

- ◆ Large 2.1 gallon (8L) or 4.2 gallon (16L) capacities
- ◆ Polished #304 stainless steel construction
- ◆ Twist-locking lid design
- ◆ Cool touch handles
- ◆ Dripless faucet with protected level indicator
- ◆ Waterproof ON/OFF switch with protective cover
- ◆ Heating and holding indicator lights
- ◆ Automatic shut-off safety feature
- ◆ One year parts and labor warranty



EWB-50A  
EWB-100A

EWB-100A-I

### Parts

|          |                                   |
|----------|-----------------------------------|
| EWCU-P3  | Faucet Assembly                   |
| EWCU-P4  | Water Gauge Assembly for EWB-50A  |
| EWCU-P5  | Water Gauge Assembly for EWB-100A |
| EWCU-P19 | Locking Lid Assembly for EWB-50A  |
| EWCU-P20 | Locking Lid Assembly for EWB-100A |

### Options & Accessories

|             |                                |
|-------------|--------------------------------|
| SGN-series  | Stainless Steel Beverage Signs |
| DT-series   | Drip Trays                     |
| VSW-series  | Push Button Beverage Servers   |
| CF-series   | Beverage Carafes               |
| VSS-series  | Coffee/Cream Servers           |
| CLO-series  | Cup & Lid Organizers           |
| CLSO-series | Cup & Lid Organizers           |

#### For California Customers

**WARNING:** Cancer and Reproductive Harm - [www.P65Warnings.ca.gov](http://www.P65Warnings.ca.gov)

### Winco®, DWL International Trading, LLC

[www.winco.com](http://www.winco.com) | [equipsales@winco.com](mailto:equipsales@winco.com)

**New Jersey Headquarters:**  
65 Industrial Road, Lodi, NJ 07644  
Tel. 1.888.946.2682 | Fax: 1.888.946.2632

**California Distribution Center**  
14950-14952 Valley View Avenue, La Mirada, CA 90638  
Tel. 1.888.946.2652 | Fax: 1.562.926.5678

**Florida Distribution Center**  
10800 NW 103rd St. Bldg 22, Ste 11, Miami, FL 33178  
Tel. 1.786.536.4656

# Winco® Commercial Water Boilers

Models: EWB-50A | EWB-100A | EWB-100A-I

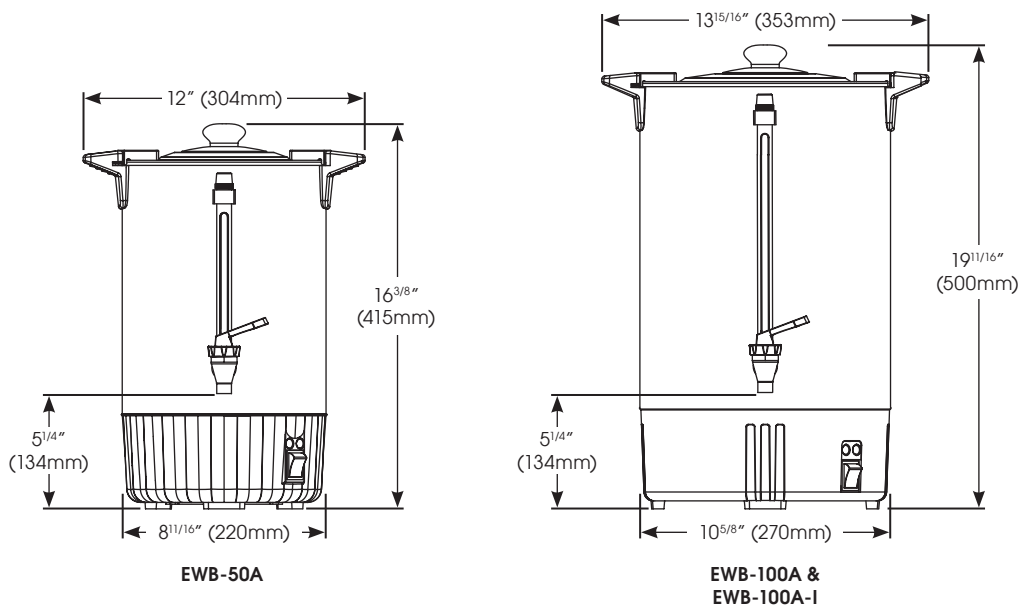

## Specifications

| MODEL      | DESCRIPTION                        | OVERALL DIMENSIONS   |                     |                      | VOLTS   | HZ | WATTS | AMPS | PLUG       | SHIP WEIGHT          |
|------------|------------------------------------|----------------------|---------------------|----------------------|---------|----|-------|------|------------|----------------------|
|            |                                    | LENGTH               | DEPTH               | HEIGHT               |         |    |       |      |            |                      |
| EWB-50A    | 2.1 Gallon (8 L)                   | 12"<br>(304mm)       | 8-11/16"<br>(220mm) | 16-3/8"<br>(415mm)   | 110-120 | 60 | 1300  | 10.8 | NEMA 5-15P | 6 lbs<br>(2.7 kgs)   |
| EWB-100A   | 4.2 Gallon (16 L)                  | 13-15/16"<br>(353mm) | 10-5/8"<br>(270mm)  | 19-11/16"<br>(500mm) |         |    | 1500  |      |            | 12.5                 |
| EWB-100A-I | 4.2 Gallon (16 L)<br>International | 13-15/16"<br>(353mm) | 10-5/8"<br>(270mm)  | 19-11/16"<br>(500mm) | 220-240 | 50 | 2250  | 9.4  | VDE        | 8.4 lbs<br>(3.8 kgs) |

## Cord Location

On back right side

## Plug Configuration

### NEMA 5-15P

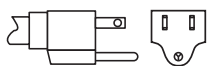

EWB-50A  
EWB-100A

### VDE



EWB-100A-I

## Product Specs Commercial Water Boiler

The Commercial Water Boilers models EWB-50A, EWB-100A, and EWB-100A-I as manufactured by Winco®, Lodi, NJ 07644.

The Commercial Water Boiler model EWB-50A with a 2.1 gallon (8L) capacity shall be rated at 1300 Watts and model EWB-100A with a 4.2 gallon (16L) capacity shall be rated at 1500 Watts. Both units are rated for 110-120V~60Hz and supplied with a NEMA 5-15P plug. Model EWB-100A-I with a 4.2 gallon (16L) capacity shall be rated at 2250 Watts for 220-240V~60Hz and supplied with a VDE plug. All units shall be constructed of polished #304 stainless steel with cool-touch handles. Units shall be equipped with a twist-locking lid, dripless faucet with protected level indicator, and waterproof ON/OFF switch with protective cover, heating and holding indicator lights, and automatic shut-off safety feature.

CE and ETL listed for safety (Canada & US).

Warranty consists of one year parts and labor.

## Winco®, DWL International Trading, LLC

[www.wincous.com](http://www.wincous.com) | [equipsales@wincous.com](mailto:equipsales@wincous.com)

**New Jersey Headquarters:**  
65 Industrial Road, Lodi, NJ 07644  
Tel. 1.888.946.2682 | Fax: 1.888.946.2632

**California Distribution Center**  
14950-14952 Valley View Avenue, La Mirada, CA 90638  
Tel. 1.888.946.2652 | Fax: 1.562.926.5678

**Florida Distribution Center**  
10800 NW 103rd St. Bldg 22, Ste 11, Miami, FL 33178  
Tel. 1.786.536.4656