



Project _____
Item # _____
Quantity _____

KATTEX

Quick Slice Chopper/Dicer

Models: HCD-250 | HCD-375 | HCD-500

The Kattex Chopper/Dicer produces perfectly diced onions, tomatoes and cucumbers too.

Standard Features

- ◆ Cast aluminum construction with stainless steel blades
- ◆ Sturdy base with non-skid feet
- ◆ 3-3/8" x 3-3/8" cutting area
- ◆ NSF listed



HCD-SERIES

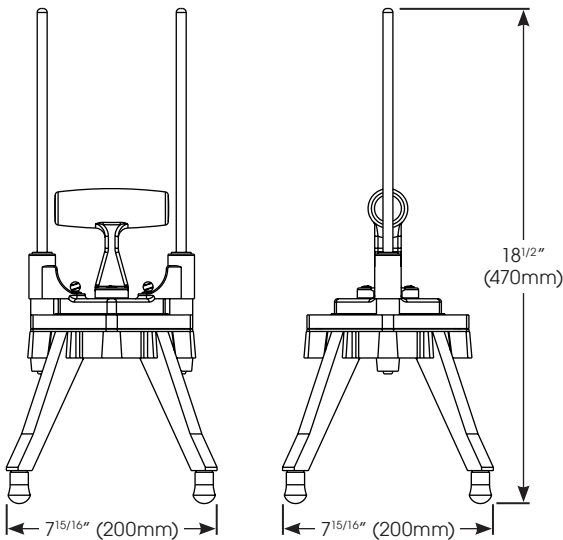

Parts & Accessories

HCD-250BK	1/4" Replacement Blade & Block for HCD-series
HCD-375BK	3/8" Replacement Blade & Block for HCD-series
HCD-500BK	1/2" Replacement Blade & Block for HCD-series
HCD-BR	2-Pc Black Rubber Ring Set
KAT-FT	4-Pc Replacement Feet Set
KAT-BS-FH	4-Pc Replacement Bushings

MODEL	DESCRIPTION	OVERALL DIMENSIONS			BOX DIMENSIONS			SHIP WEIGHT
		LENGTH	DEPTH	HEIGHT	LENGTH	DEPTH	HEIGHT	
HCD-250	1/4" Blade Dicer	7-15/16" (200mm)	7-15/16" (200mm)	18-1/2" (470mm)	8-1/2" (215mm)	8-1/2" (215mm)	19-15/16" (505mm)	7.05 lbs (3.2 kg)
HCD-375	3/8" Blade Dicer							
HCD-500	1/2" Blade Dicer							

Product Specs

Quick Slice Chopper/Dicer

The Quick Slice Chopper/Dicer models HCD-250, HCD-375, and HCD-500 as manufactured by Winco®, Lodi, NJ 07644.

The Quick Slice Chopper/Dicer shall be constructed of aluminum with stainless steel blades. Units are equipped a sturdy base with non-skid feet and have a 3-3/8" x 3-3/8" cutting area. Units are NSF listed.

For California Customers

WARNING: Cancer and Reproductive Harm - www.P65Warnings.ca.gov

Winco®, DWL International Trading, LLC

New Jersey Headquarters:
65 Industrial Road, Lodi, NJ 07644
Tel. 1.888.946.2682 | Fax: 1.888.946.2632

California Distribution Center
14950-14952 Valley View Avenue, La Mirada, CA 90638
Tel. 1.888.946.2652 | Fax: 1.562.926.5678

Florida Distribution Center
10800 NW 103rd St. Bldg 22, Ste 11, Miami, FL 33178
Tel. 1.786.536.4656

www.winco.us.com | equipsales@winco.us.com