

**T&S BRASS AND BRONZE WORKS, INC.**  
 2 SADDLEBACK COVE / P.O. BOX 1088 / TRAVELERS REST, SC 29690  
 PHONE 800-476-4103

8940 HWY 147W, ROCHESTER, MN 55901



Model No.

B-0413

Item No.:

Job Name:

Architect/Engineer Approval:

Notes:

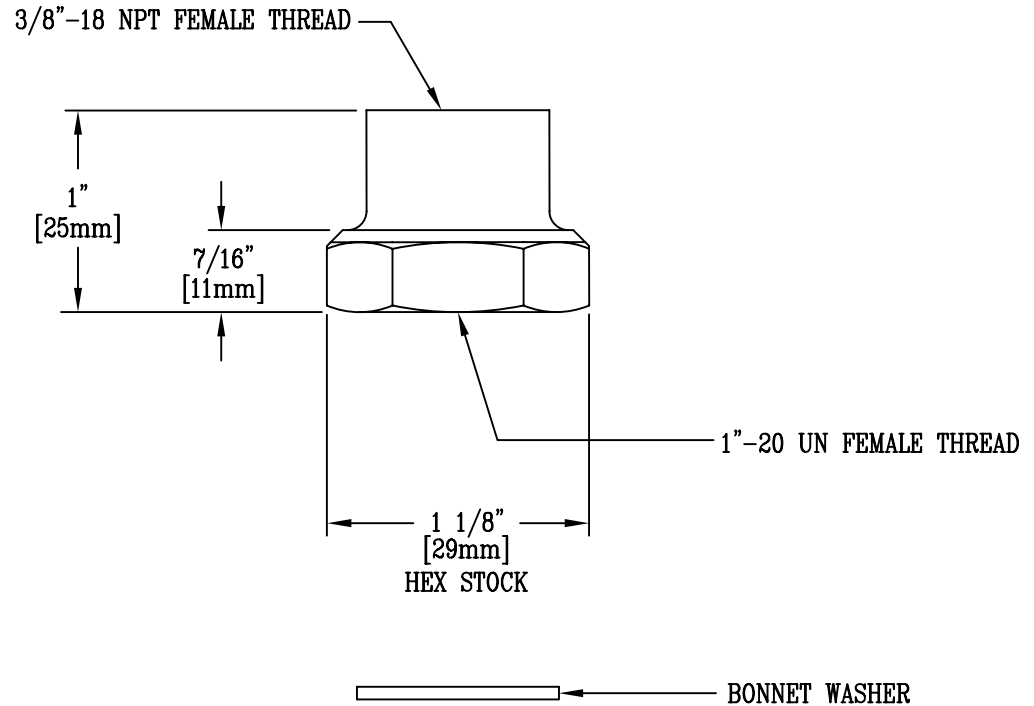

Product Description:

1"-20 UN FEMALE THREAD x 3/8"-18 NPT MALE  
 THREAD SWIVEL TO RIGID ADAPTER PIECE w/  
 BONNET WASHER

Drawn:

KJG

Approved

JHB

Checked

DHL

Scale:

1' = 1"

Date:

11/11/08